

SNAPPER Remote Boat Latch

INSTALLATION INSTRUCTIONS

READ THOROUGHLY BEFORE BEGINNING INSTALLATION



WARNING!!

1. DO NOT CONNECT TO POWER SOURCE UNTIL ALL WIRING IS COMPLETE.
2. DISCONNECT FROM POWER SOURCE BEFORE MAKING ANY CHANGES TO THE WIRING OR WHILE INSTALLING OPTIONAL AUDIO INDICATOR.
3. DO NOT TOUCH POSITIVE AND NEGATIVE WIRES TOGETHER WHILE CONNECTED TO A POWER SOURCE.
4. ANY DISASSEMBLY OF THE UNIT OR COMPONENT MODIFICATIONS WILL VOID THE LIFETIME WARRANTY.

FOR INSTALLATION ASSISTANCE OR QUESTIONS CALL: 1-800-879-3726

Please review your trailer winch post style. The SNAPPER Boat Latch will fit upright supports up to 4" in width (spacer bushings may be required to take up space differential)

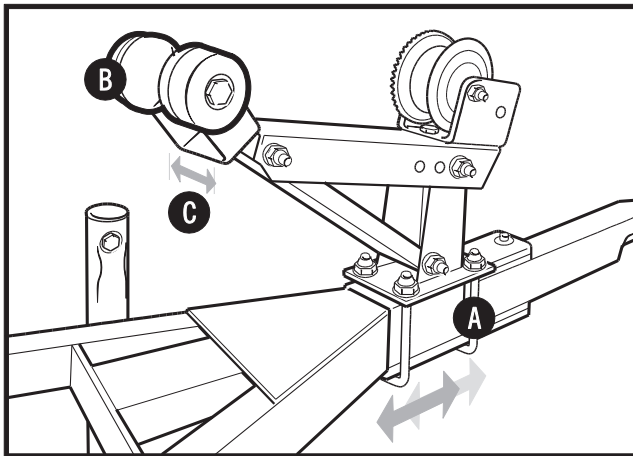

TYPICAL WINCH STYLE

PARTS LIST

- 1 SNAPPER™ Boat Latch Assembly
 - 1 LED Light Pole Assembly
 - 1 Keychain FOB
 - 1 Lock Pin
 - 1 Hairpin Clip
 - 2 16-22 AWG Wire Butt Splices
 - 1 3" Plastic Tube (Spacer Bushings)
 - 1 3/8"-16 Hex Lock Nut
 - 1 L-Bracket (Optional Mount for Light Pole)
 - 1 10-32 Hex Head Machine Screw
 - 1 10-32 Hex Head Lock Nut
 - 1 Warranty
 - 1 Installation Instructions
 - 1 SNAPPER Compact Disc
- Replacement Bow Eye:**
- 1 Stainless Steel Extended Bow Eye
 - 2 Acorn Nuts - for exterior
 - 2 Mounting Plates
 - 2 Hex Nuts - for interior

A. INSTALLING THE SNAPPER Begin installation with the boat on the trailer. Attaching the SNAPPER Boat Latch may require adjustments to the trailer winch assembly. Before beginning, always work from a dry and level position. Be sure the boat is safely secured to the trailer before beginning any position adjustment to the winch or hardware.

boat on the

1. Loosen winch stand assembly connecting bolts (A) to allow parallel movement along the trailer beam. Back the stand away from the boat. 2. Remove the roller/V block from its support. The SNAPPER Boat Latch requires 1/2" mounting holes in the roller/V block support (B). 3. Measure the inside spacing between the uprights of the roller/V block support (C). If center spacing is 3", no bushing is required. If the center spacing is greater than 3", make the spacer bushings from the 3" Plastic Tube provided. Subtract 3" from the inside measurement of the upright roller supports. Divide that number by 2 and cut two spacers of that length from the Plastic Tube.

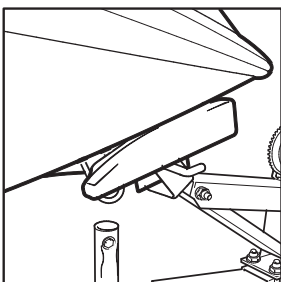

4. The SNAPPER is intended to be used with a stainless steel, U-bolt style Bow Eye only. The Bow Eye should extend 1" – 1 1/2" below the SNAPPER jaws measured with the boat in the trailering position. It may be necessary to install an extended Bow Eye on the bow of the boat to insure sufficient length for winch strap tie down of the boat for boat trailering. An extended 1/2" U-bolt style stainless steel Bow Eye with mounting hardware is included. The winch strap can be fed through the underside of the SNAPPER and attached to the extended Bow Eye protruding below the SNAPPER jaws.

B. EXTENDED BOW EYE INSTALLATION

(For boats not equipped with extended Bow Eyes)

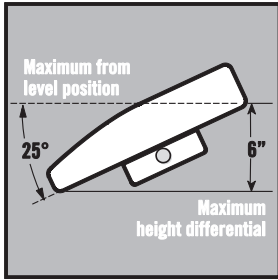

fig. 1 NOTE: The winch strap must be secured to the boat's Bow Eye for highway trailering as well as securing the stern tie downs.

1. Remove the existing hardware retaining the OEM Bow Eye. It may be necessary to remove interior bow cover panels to access the retaining hardware. 2. Pull the OEM Bow Eye out of the existing mounting holes carefully. 3a. Model 16-SNAPPER-1: Boats equipped with a 3/8" diameter steel Bow Eye will use the 1/2" diameter extended U-bolt included in the kit. The hole centerline spacing of the U-bolt legs is 1 3/8". You will need to drill the existing holes in the hull larger to a 17/32" diameter to facilitate the larger diameter EPCO Bow Eye. Install the retaining hardware provided. 3b. Model 16-SNAPPER-2: Boats already equipped with a 1/2" diameter steel Bow Eye can simply insert the EPCO extended Bow Eye into the existing holes and install the retaining hardware provided. 4. Torque the Bow Eye retaining nuts to 10-15 ft/lbs.

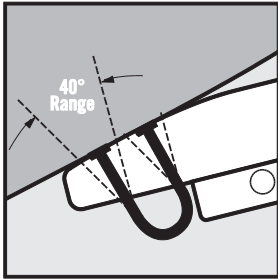

fig. 2

C. POSITIONING THE SNAPPER. 1. Pivot the SNAPPER to a horizontal position with the V-notch toward the bow of the boat. Pull the slide bar on the underside of the SNAPPER back away from the bow of the boat until you hear and feel a catch in the extended position (the jaws have now been manually set in the release/catch position). 2. Slide the entire winch stand assembly toward the bow of the boat. The Bow Eye must pass through the jaws of the SNAPPER and latch securely. 3. Observe the horizontal position of the SNAPPER. The front of the SNAPPER should never be tipped down at an angle more than 25° from a horizontal plane. (Fig. 1) If the front is horizontal or pointed upward, loosen and reposition the roller / V block support to a higher point on the winch stand.

4. The SNAPPER jaws must be aligned with the bow eye in a plane parallel to and equal in height to the waterline (see Fig. 4 on page 3) before Launching and perpendicular within 20° to the boat bow eye. (Fig. 2) Re-secure the roller/V block support.
5. The SNAPPER is weighted to allow the unit to pivot around the 1/2" mounting hole. It may be necessary to drill a thru hole and install a bolt (10-32 machine screw and lock nut provided) in the roller/V block support to act as a stop to maintain proper SNAPPER position.
6. Secure all bolts of the winch assembly base.
7. The SNAPPER is not intended to replace the weight bearing function of the lead rollers, v-cradle or bunks of the trailer.
8. A winch strap, safety chain and transom tie downs are required to secure the boat for over the road trailering.

D. WIRING INSTRUCTIONS.*

1. DO NOT CONNECT TO TRAILER LIGHT CIRCUIT. SNAPPER requires a 12-volt DC power source which can be supplied from the tow vehicle. A separate wiring connector adapter may be required to provide the 12-volt DC source from the tow vehicle to the trailer. It is required to supply the 12-volt DC for the red wire from a 10 amp fused connection at the tow vehicle fuse panel. Vehicles equipped with a factory installed, pre-wired 7 way towing package may already have a 12-volt DC auxiliary power connection available, thereby eliminating the need to run a separate wire to the fuse panel.

WARNING!!

1. DO NOT CONNECT TO POWER SOURCE UNTIL ALL WIRING IS COMPLETE.
2. DISCONNECT FROM POWER SOURCE BEFORE MAKING ANY CHANGES TO THE WIRING OR WHILE INSTALLING OPTIONAL AUDIO INDICATOR.
3. DO NOT TOUCH POSITIVE AND NEGATIVE WIRES TOGETHER WHILE CONNECTED TO A POWER SOURCE.
4. ANY DISASSEMBLY OF THE UNIT OR COMPONENT MODIFICATIONS WILL VOID THE LIFETIME WARRANTY.

2. The black ground wire can be attached to any bare metal part of the trailer frame.

3. Press the button on the remote control fob to confirm proper wiring. The LED Light Pole will begin to flash continuously and the slide bar will mechanically set with an audible 'click' indicating the SNAPPER jaws are unlocked and in the proper position to launch or catch the Boat Bow Eye. Pass a rod or screwdriver through the jaws of the SNAPPER to lock the mechanism. The LED Light Pole will turn off indicating a locked position.

* The 12V power connection on the OEM 7 way trailer connection may not be activated from the factory even if the trailer towing package was ordered with the vehicle. Please check with the vehicle manufacturer/Dealer for instructions to activate the circuit.

E. LED LIGHT POLE ASSEMBLY

The LED Light Pole serves as an operational status indicator and directional guide for the boater.

Option 1: If adequate bow clearance exists between the nose of the boat and the SNAPPER LED Light Pole mounting hole:

1. Feed the LED Light Pole wires through the 3/8" mounting hole located at the back of the SNAPPER.
2. Insert the LED Light Pole Assembly into mounting hole, feed the wires thru the 3/8"-16 Lock Nut and tighten nut on LED Light Pole to secure in place.
3. Connect the wire connectors from the SNAPPER to the LED Light Pole Assembly.

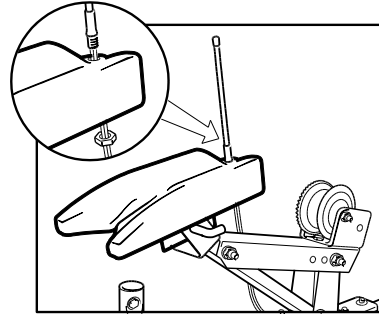

Option 1

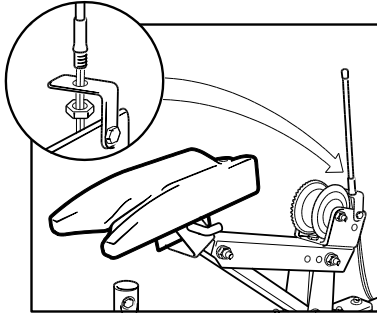

Option 2:

Option 2: If the clearance between the boat and the SNAPPER LED Light Pole mounting hole is NOT adequate:

1. Mount the L-bracket with 3/8" hole (provided) to a remote location on the trailer winch stand, preferably in line with the nose of the boat.
2. Attach the LED Light Pole Assembly to the L-bracket using the 3/8"-16 Lock Nut provided.
3. Connect the matching color wire connectors from the SNAPPER to the LED Light Pole Assembly.

F. BEFORE LAUNCHING

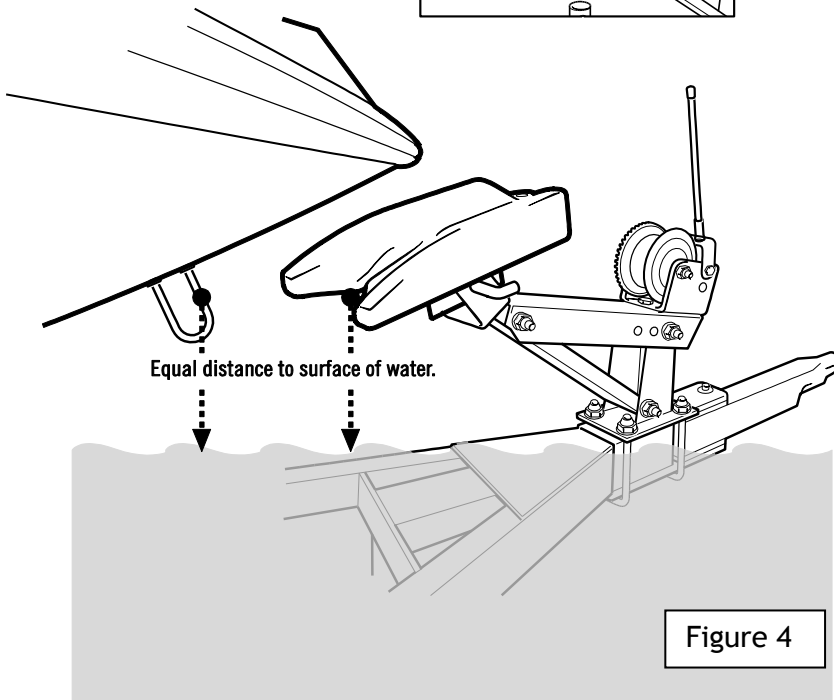
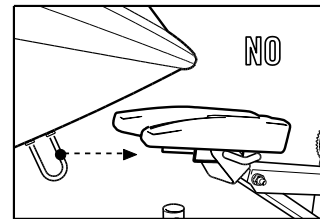
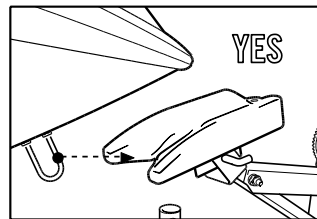

1. Observe the relative position of the Boat Bow Eye to the SNAPPER while the boat is on the trailer.
2. Maintain a similar position relationship when the trailer is in the water.
3. The distance from the SNAPPER jaws to the waterline should be approximately the same distance as the Boat Bow Eye is to the waterline when the boat is floating in the water.
4. Marking a visual indicator on the trailer winch stand when the proper trailer depth is achieved may help in future releasing and catching (see illustration below).
5. Carefully release and catch the boat with the installed SNAPPER.

REMOTE CONTROL FOB REPLACEMENT

Call our Help Line to order: 800-879-3726
Additional information can be found on our web page:

www.snapperboatlatch.com

NEW AUDIBLE ALERT OPTION

There is an optional audible signal that may be used in addition to the light pole. The audible signal begins beeping when the remote control FOB is activated and beeps at the same rate as the flashing lights on the guide pole.

For more information and price:
1-800-879-3726.



Made in the USA

**EPCO Products, Inc.
PO Box 9250
3736 Vanguard Drive
Fort Wayne, IN 46899-9250
260-747-8888 Fax: 260-747-6699**

www.snapperboatlatch.com